

INTEGRA PRE-INSTALLATION CHECKLIST

THIS FORM MUST BE COMPLETED AND SUBMITTED TO CONCORDIA BEFORE INSTALLATION WILL BE SCHEDULED
FAX NUMBER 1-425-453-1490 - ATTENTION INSTALLATION COORDINATOR

The installation visit includes the following: set-up, test, calibration, and customer training. If more than one visit is required to complete the installation due to unprepared site, return visits will be billable at **\$250.00** each.

Company Name		IF APPLICABLE, PLEASE SUPPLY
Contact Name		Construction Company Name
Site Address		Construction Contact Name
Billing Address		
Phone		Phone
Fax		Fax

SITE PHYSICAL REQUIREMENTS

<input type="checkbox"/>	<p>LOCATION: The countertop must support at least 300lbs. Minimum countertop space: 25" (64cm) W x 29" (74cm) D x 34" (86cm) H. Actual machine dimensions are smaller, extra space is required for Service Access. Access holes for the drain and water hoses must be cut into the countertop. See Access Holes Diagram.</p> <p>For Cabinet Installations: Proper air circulation, ventilation, and accessibility needs must be met. The air going into the machine must not exceed 85°F (29°C). The machine must be moveable. If you are installing in a cabinet or other enclosed space, please contact Concordia prior to installation.</p>
<input type="checkbox"/>	<p>ELECTRICAL: NEMA L6-30R receptacle. Minimum 208Vac on dedicated 30amp circuit. <u>Must be located within five feet of machine.</u></p>
<input type="checkbox"/>	<p>WATER: Cold water source with a female 1/4" or 3/8" tube fitting and shut-off valve. Min. 30psi, Max. 100psi, 25gpm. If your location has a Reverse Osmosis System, a freshwater bypass is required. Water hardness must not exceed 3gpg.</p>
<input type="checkbox"/>	<p>WATER TREATMENT SYSTEM: Space must be available to install water treatment system. <u>Must be located within five feet (1.5 meters) of machine.</u> Dimensions: 14" (36cm) W x 6" (16cm) D x 18" (46cm) H. Unit is mounted on the wall.</p>
<input type="checkbox"/>	<p>DRAIN: Connection for a 3/4" (1.9cm) ID drain hose. <u>Must be located within five feet (1.5 meters) of machine.</u></p>
<input type="checkbox"/>	<p>AMBIENT AIR TEMPERATURE: The air temperature around the machine must not exceed 85°F (29°C), to ensure the refrigeration unit and the machine operate properly.</p>

INTEGRA INSTALLATION DIMENSIONS

Actual machine dimensions are smaller

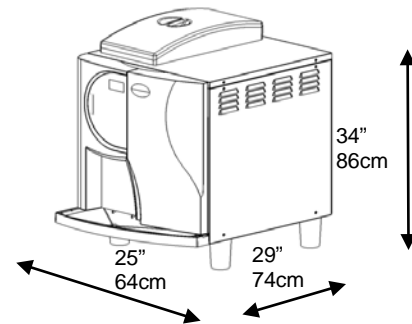

ELECTRICAL

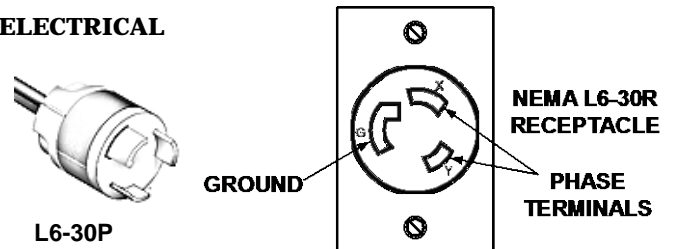

CUSTOMER SUPPLIED CONSUMABLES

<input type="checkbox"/>	BEANS	Whole espresso beans (regular and decaf). Minimum 5lbs each.
<input type="checkbox"/>	MILK	1 gallon milk (e.g. 2%, 1%, or non-fat)
<input type="checkbox"/>	CUPS	Two sizes (e.g. 8oz/240mL and 12oz/360mL). Minimum 30 each.

WATER TREATMENT SYSTEM DIMENSIONS

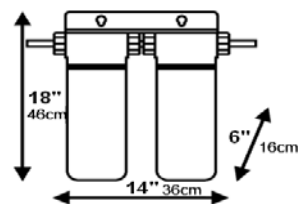

I HAVE READ AND UNDERSTAND THIS DOCUMENT & CONFIRM THESE **REQUIREMENTS HAVE BEEN MET**. Make copy for your records.

Customer Name (Print): _____ Title: _____

Customer Signature: _____ Date: _____

Access Holes Diagram

Connection for a 3/4" (1.9cm) ID drain hose must be located within five feet (1.5 meters) of the machine. The location may require a drain hose access hole be cut in the counter top. This must be completed prior to installation.

